

Compact Spin Coater Brochure

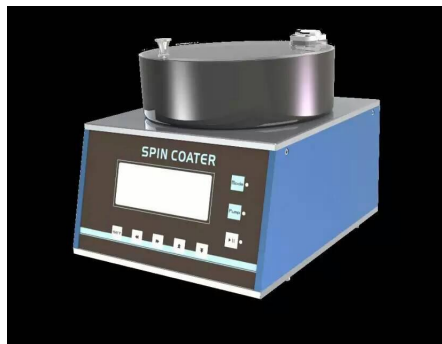

Contents

1.Brief introduction.....	3
1.1 Product Info.....	3
1.2 Safety.....	3
2.Installation.....	3
2.1 Technical parameter.....	4
2.2 Package checking.....	4
2.3 System installation and setting.....	4
2.3.1 Installation Space.....	4
2.3.2 Installation procedure.....	5
3.System Running.....	5
3.1 Coating base.....	5
3.2 Panel introduction.....	6
3.3 Quick Run.....	7
3.4 Program Run.....	7
4.Repair and Maintenance Services.....	8
4.1 Equipment clean.....	8
4.2 Replace fuse wire.....	9
4.3 Replace the plate.....	9
4.4 Malfunction Elimination.....	9

1. Brief Introduction

1.1 Product Info

Before operate the spin coater please read and understand the brochure carefully! Only with relevant operational knowledge of qualified personnel are allowed to use, Incorrect operation and maintenance without permission are likely to cause serious injury.

1.2 Safety

Ensure user's safety, before using the spin coater, please not the following precautions

- Spin coater isn't a flameproof equipment, it is forbidden operate it in a easy explosion and danger space.
- Strictly forbids the use of flammable, explosive and radioactive material plastic operation
- When the machine is working, make sure the plastic cover is closed, during the working period, please don't open the cover to prevent the user from hurts.

Safety Norms

- Before the equipment is installed proper, please don't operate it
- When the equipment is changed without permission, please don't operate it
- Please don't use corrosion and mechanical damage plate in the spin coater
- When the machine is working, please don't touch, grasping the plate
- When the machine is working, please don't open the plastic cover to prevent the user from wafer's hurt
- When the power is connected, please don't open the backside cover
- Before eliminate the equipment, please make sure the power is off
- Ensure user's safety, please make sure the equipment ground wire is connected properly

2. Installation

Compact Spin coater is a small and smart spin coater, it is adopted Brushless DC motor to make sure high precision, low noise. It is suitable for 4 " wafer's spin coating. The programmable system can restore 5 unit programmable, and each programmable can store 5 steps. All of the Running Parameter, such as rotating speed, acceleration and rotate time can show on the panel

2.1 Technical Parameter

Model No.	EZ4
Maximum speed	8000RPM
Speed Resolution	1 RPM
Maximum Rotating Time	3000s
Time Resolution	1 s
Maximum Acceleration	8000RPM/S
Wafer diameter	1cm-150mm
Motor Power	75w
Dimension	210*250*210mm
Gross Weight	10Kg
Working voltage	AC 220V, 50hZ
Vacuum request	0.06~0.09Mpa, 15L/min
Vacuum interface	5mm
Fuse	2A

2.2 Package checking

When you receive the equipment, please open the package and check whether the equipment is damage or not. If the equipment has been damaged, please don't operate it and contact with us immediately.

In general, packing list as below:

- Spin Coater 1set
- Electric wire 1 piece
- Manual Book 1 piece
- Cartridge Fuse 1 piece
- Plate 1 set

2.3 System installation and setting

Please take the Spin coater from the bottom of the package, and make sure do not put the equipment upside down. After take out the equipment, please remove the plastic cover and clean the bowl and plate properly.

2.3.1 Installation Space

- Spin coater should be putted on smooth and solid work surface
- Spin coater should not be installed in heating, strong sunlight area

- When spin coater is working, User should be away 30cm distance between the equipment to avoid harmful substances hurt.

2.3.2 Installation procedure

- When start using the equipment, should first connect the vacuum pump from the equipment backside interface
- Connect with electric power
- Switch on the backside switch
- Open the vacuum pump

3.System Running

3.1 Coating base

Choose the correct plate

Considering the good uniform adhesive effect, we suggest the coating wafer should not bigger two times than the plate.

Standard Circular Plate is recommended to use in a small, light square on the substrate. If the sample is too large or heavy, we suggest use the embedded plate or customized lever block plate.

Put the sample on the plate center

Before start coating, please make sure the sample is loaded on the center of the plate

Rotating and accelerating

For regular sample, we suggest the spin coater's maximum rotating speed set as 5000RPM and the maximum accelerating speed set as 5000RPM/S. If the sample's thickness and weight is too larger, for safety operating, we should reduce the maximum speed and accelerating, and we suggest use the embedded plate or customized lever block plate.

Rule of Thumb

In general, when the equipment start coating, we suggest using low rotating speed (1000RPM) and accelerating speed (1000RPM/S) to make sure the sample is adsorbed on the plate, and confirm the sample is putted on the center of the plate.

3.2 Panel introduction

EZ4 Spin coater has two operating mode: "QUICK RUN" and "PROGRAM RUN". When the machine is power on, the program will go into :QUICK RUN mode by default.

Panel as below:

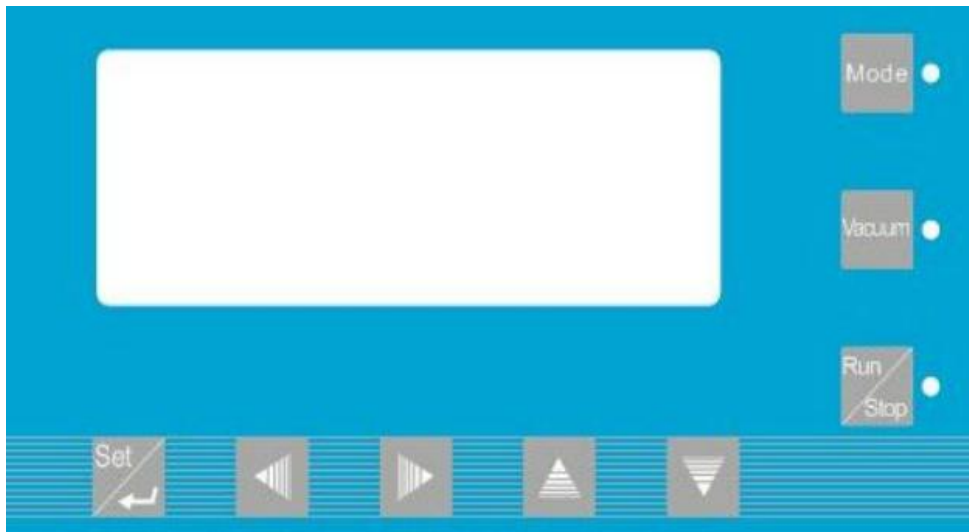

Instruction of buttons

Mode: Operating Mode Switch Button(Quick Run/Program Run)

Vacuum:vacuum open/close button

Run/Stop:Run/stop the system

Set: Parameter setting



Shift key can choose/set “speed,time or acceleration”

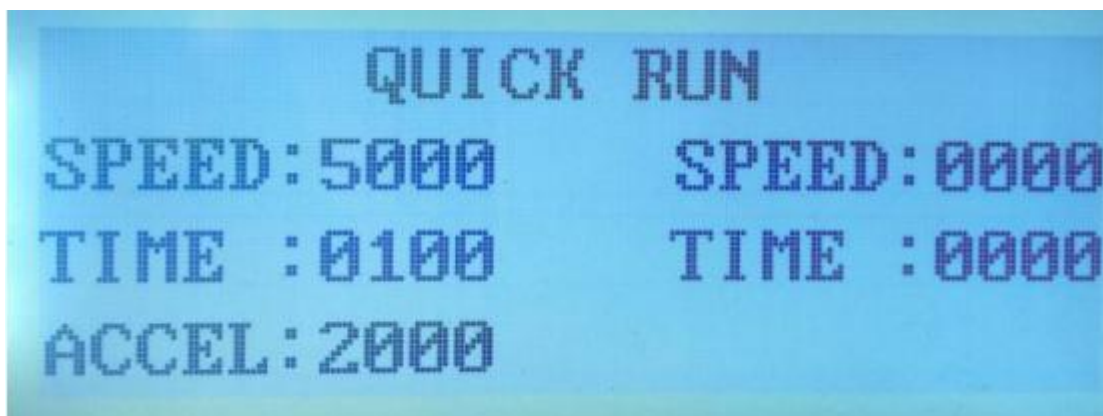

3.3 Quick Run

Quick Run mode show as below:

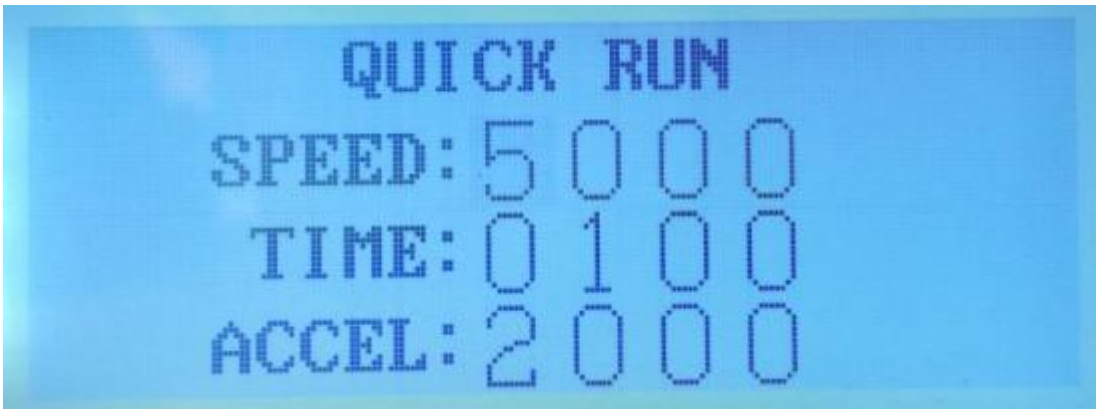

Long press “set” button to enter parameter setting interface as below:

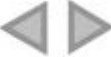

Press  button to choose and set SPEED, TIME, ACCEL, Press  to modify the corresponding data, finish setting, long press "set" button back to the main interface

User can trough "Vacuum" button manual operate the vacuum pump and test the adsorption condition. Press "RUN/STOP" button to start or stop coating. Once start coating, user neither can operate "Vacuum" button nor modify the "Mode"



After setting the parameter, user can press "Run/Stop" button to start or stop coating". Before start coating, please make sure the vacuum system is connected properly

3.4 Program Run

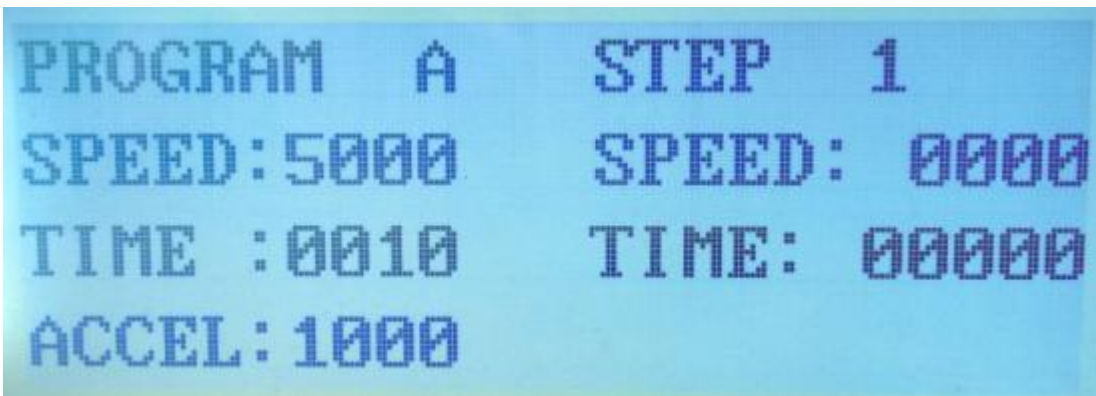
Compared with QUICK RUN, Program Run can process multi-step programmable coating. User can pre-set programmable, then system will start coat following the pre-setting programmable automatically. In "quick Run" mode, press "Mode" button, the system will enter "Program Run" Mode as below:



The system pre-store A,B,C,D,E five programmable, each programmable can edit 1,2,3,4,5 steps.

User can press  button to choose Programmable, and press  button to choose step. Long press “SET” enter the chosen programmable and set the parameters as below. Short press” SET” TO modify the Step parameter. Finish setting, long press “SET” back to main interface, press” RUN/STOP” to start or stop coating



4.Repair and Maintenance Services

4.1Equipment clean

After using the equipment, please use suitable solvent clean the plate and chamber. Before clean the vacuum plate, please close the vacuum system first, use soft cloth clean the plate surface.

When the plate is installed on the chamber, use solvent clean the plate is forbidden, it may damage the vacuum system and spin coater

4.2 Replace fuse wire

The fuse wire is installed in the fuse holder, Replace fuse wire way as below:

- Close the equipment, remove the power supply plug,wait for 10 minutes
- Open the fuse holder cover, take out the fuse wire
- Put the new fuse wire inside, and fix the fuse holder cover as below:

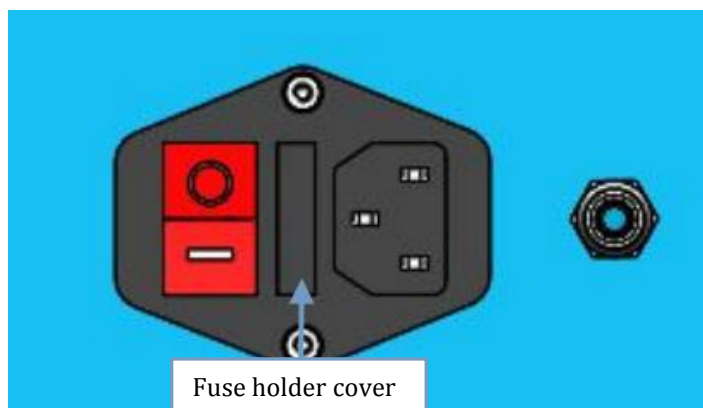

4.3 Replace the plate

- Close the vacuum system
- Take the plate from the axis
- Put the new plate on the axis, make sure the slot is properly aligned locating pin
- Make sure the plate is located on the shaft, there is no gap between the plate and shaft.

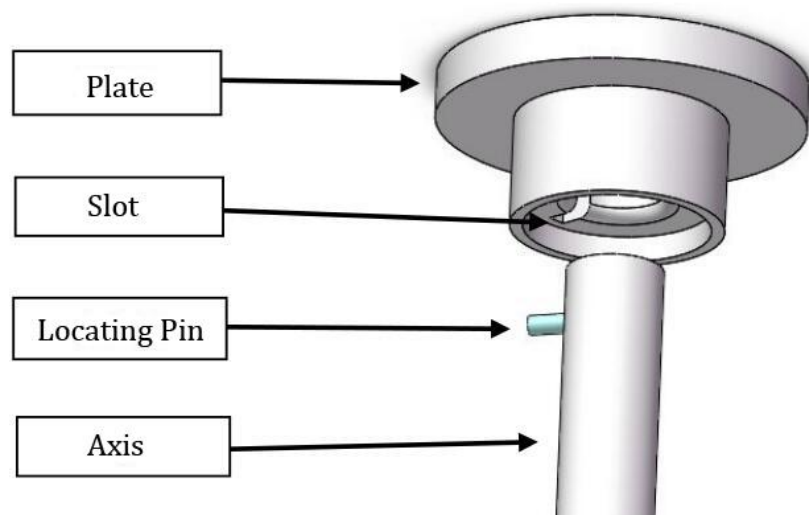

4.4 Malfunction Elimination

➤ **Spin coater can't switch on**

Reason 1: No power supply

Shooting: check the power supply, or the fuse wire

Reason2: the fuse wire is melting

Shooting: check the fuse wire, if yes, replace a new fuse wire

➤ **Spin coater can't work, power supply is correct**

Reason 1: The SPEED, TIME and acceleration didn't set

Shooting: check the mode and set the suitable speed/time/acceleration

Reason2: the fuse wire is melting

Shooting: check the fuse wire, if yes, replace a new fuse wire

➤ Program began to work, then automatic stop

Reason 1: Program setting isn't correct

Shooting: check the programmable, if need, re-edit the programmable

➤ Spin coater is vibrated or noise is too low

Reason 1: Equipment damage

Shooting: contact with after sale service

Reason 2: Spin coater didn't install properly

Shooting: check whether the spin coater is installed on horizontal level, if not, please put the spin coater on a smooth horizontal level space.

Dimension:

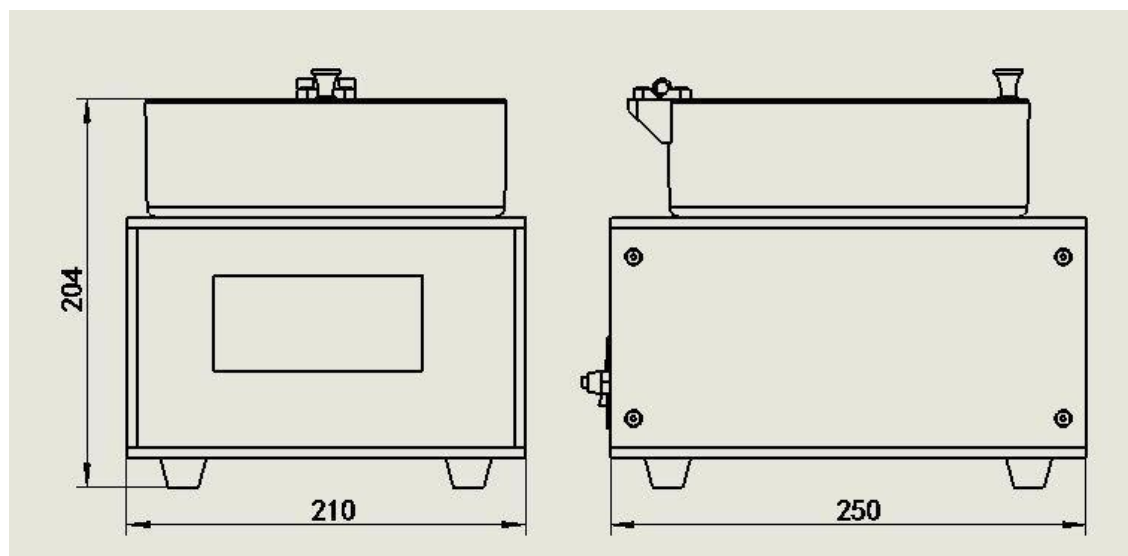

Any technical question, please contact us via: +86 13164339149